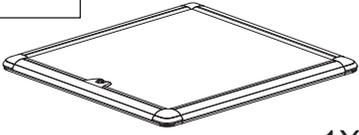
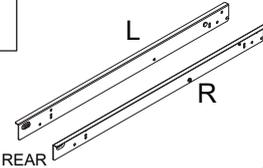
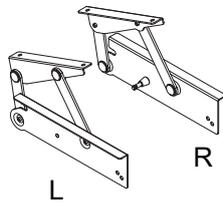
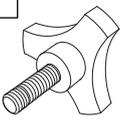
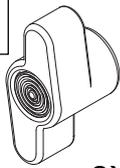
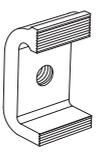
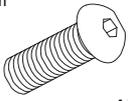
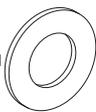
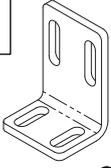
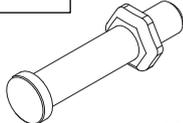
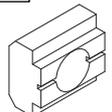
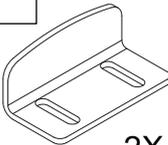
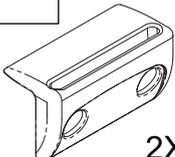
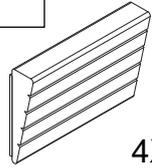
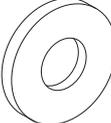
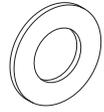
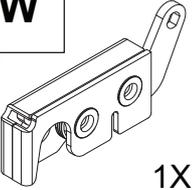
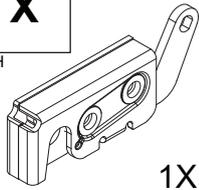
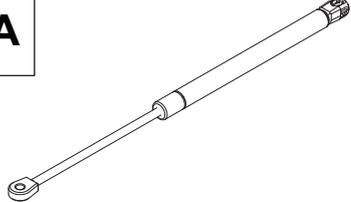
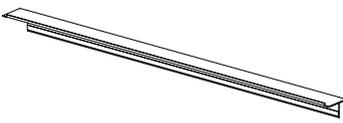
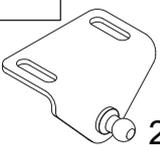
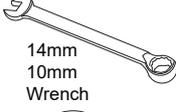
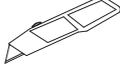
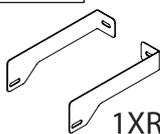
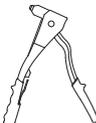
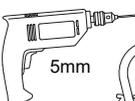
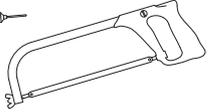

# UpStoneEvolve

INSTALLATION INSTRUCTIONS K408

MITSUBISHI L200 2016+ double cab  
FIAT FULLBACK 2016+ double cab

<b>A</b>  1X	<b>B</b>  REAR L R 1X	<b>C</b>  L R 1X	<b>D</b>  2X
<b>E</b>  2X	<b>F</b>  4X	<b>G</b> M8x25mm  4X	<b>H</b> M8 x16 Stainless Steel Washer  6X
<b>I</b>  2X	<b>J</b> M8 Nylock  4X	<b>K</b> M8 Stainless Steel Spring Washer  2X	<b>L</b>  2X
<b>M</b>  2X	<b>N</b>  2X	<b>O</b>  2X	<b>P</b> M6x20  18X
<b>Q</b> M6x13mm Zinc  20X	<b>R</b> M6x10mm  12X	<b>S</b>  4X	<b>T</b>  4X
<b>U</b> M10x24mm  4X	<b>V</b> M8 x16 Zinc Washer  8X	<b>W</b> RH  1X	<b>X</b> LH  1X
<b>Y</b> M5 Cable Bolt, Washer & Dome Nut  2X	<b>Z</b>  2X	<b>AA</b>  2X	
<b>AB</b>  1X	<b>AC</b>  2X	<p><b>Note 1:</b> If at any stage of installation you find your sportlid to be an unacceptable fit please contact the manufacturer before continuing.</p> <p><b>Note 2:</b> If required, use Under Rail Bed Liner only. <b>NOT FOR USE WITH OVER RAIL BED LINER!</b></p> <p><b>Tools Required:</b></p>     	
<b>AD</b>	<b>AE</b>	<b>AF</b>  1XR 1XL	<b>AG</b> M6x18  2X
<b>OPTIONAL</b> 			 5mm 

<b>Fitting Kit Number</b> K408	<b>Product</b> Upstone Lid	<b>Revision</b> 3	<b>Date</b> 26-11-2019	<b>Page</b> 1 of 8
-----------------------------------	-------------------------------	----------------------	---------------------------	-----------------------



WARNING If bedliner front panel is over rail CUT IT OFF

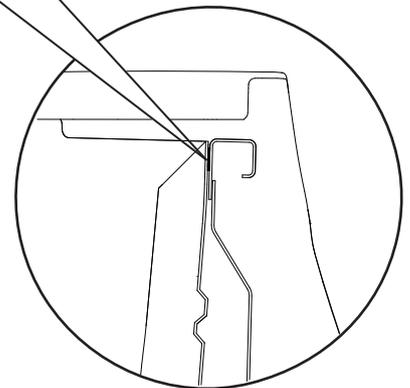
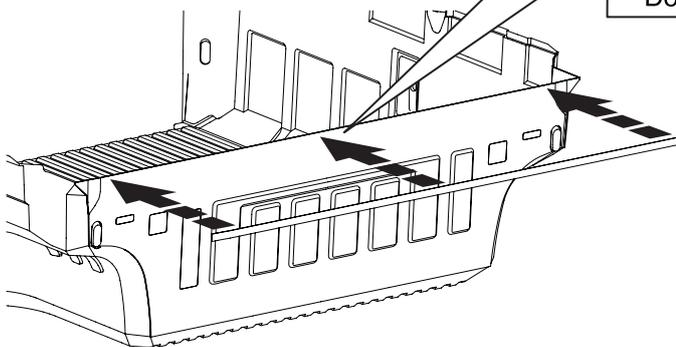
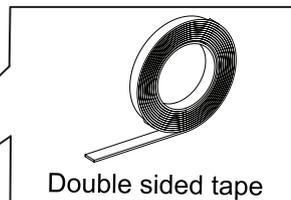
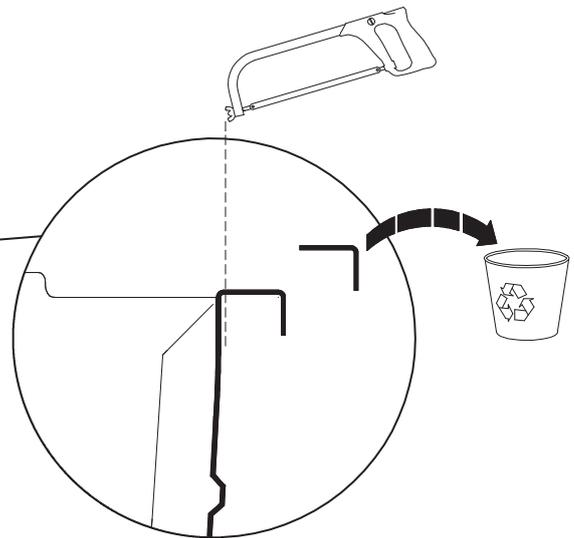
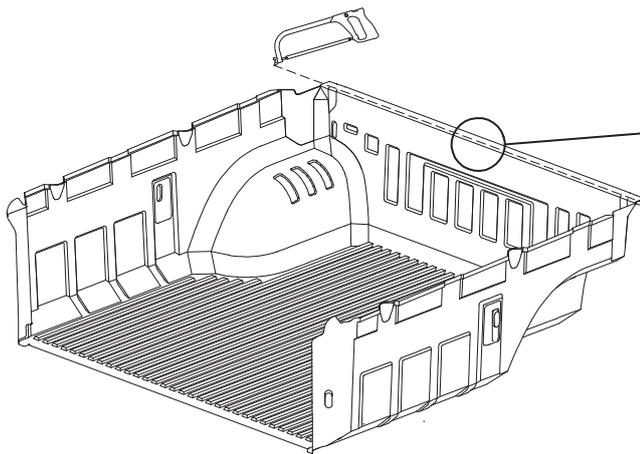
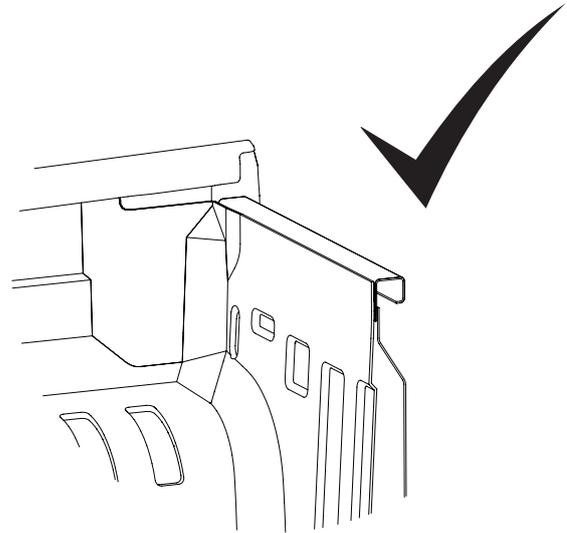
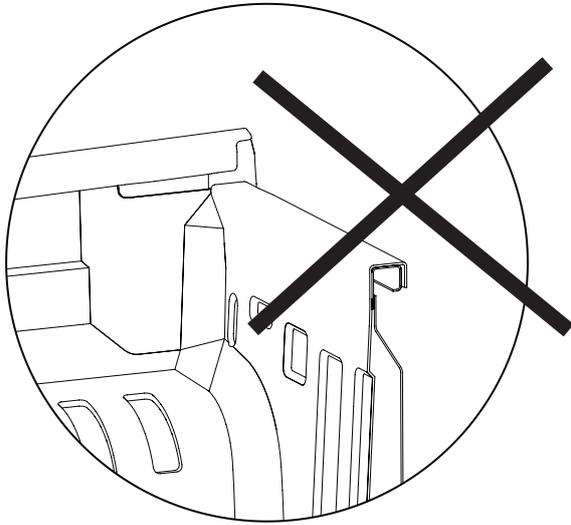

Fitting Kit Number	Product	Revision	Date	Page
K408	Upstone Lid	3	26 -11-2019	2 of 8

1

Remove ladder rack

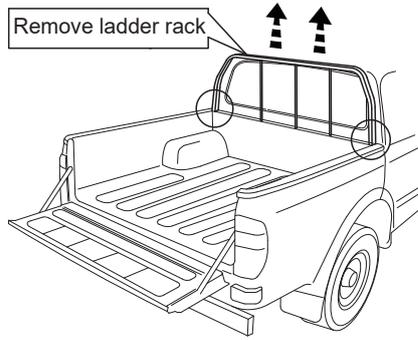

Note 2: If required, use Proform Under Rail Bed Liner only. Not for use with Over Rail Bed Liner.

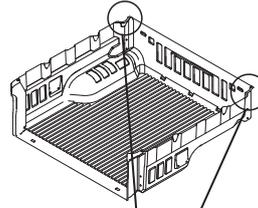

Follow guide lines to trim liner in front corners.

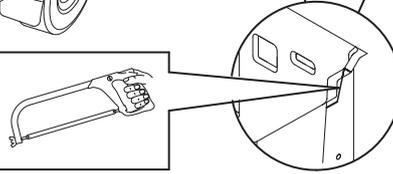

2

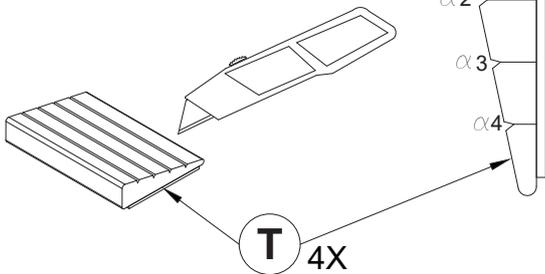
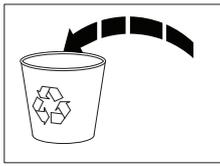

Vehicle Model	$\alpha$
Mitsubishi L200 Double Cab 2016+	2

3

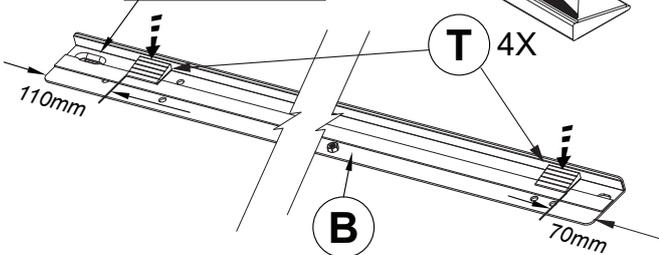
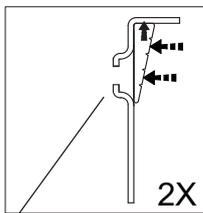

4

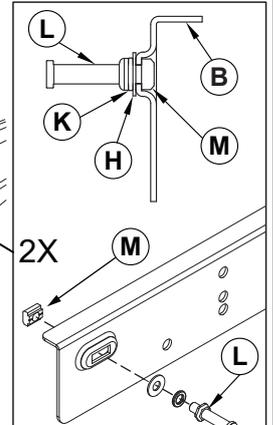
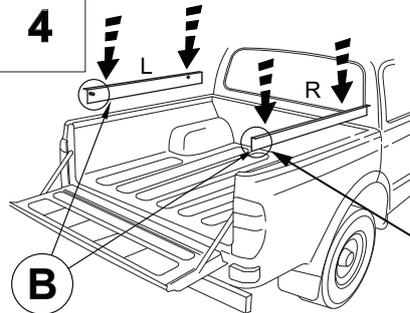

FINGER TIGHTEN ONLY

5

Place front of side mounting brackets back from inside corners of the cargo box - See table for measurement

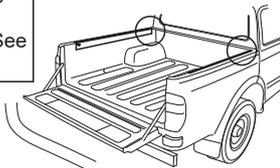

Vehicle Model	$\beta$	$\delta$	$\varphi$
Mitsubishi L200 DC 2016+	65-75mm	1	5

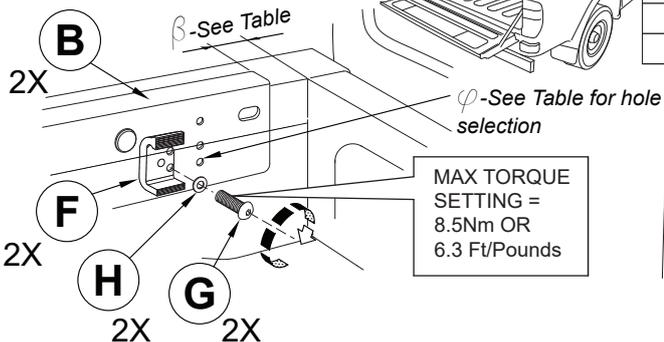

MAX TORQUE SETTING = 8.5Nm OR 6.3 Ft/Pounds

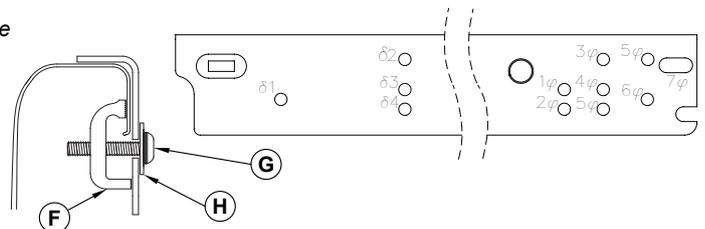

Fitting Kit Number  
K408

Product  
Upstone Lid

Revision  
3

Date  
26-11-2019

Page  
3 of 8

6

Ø -See Table for hole selection

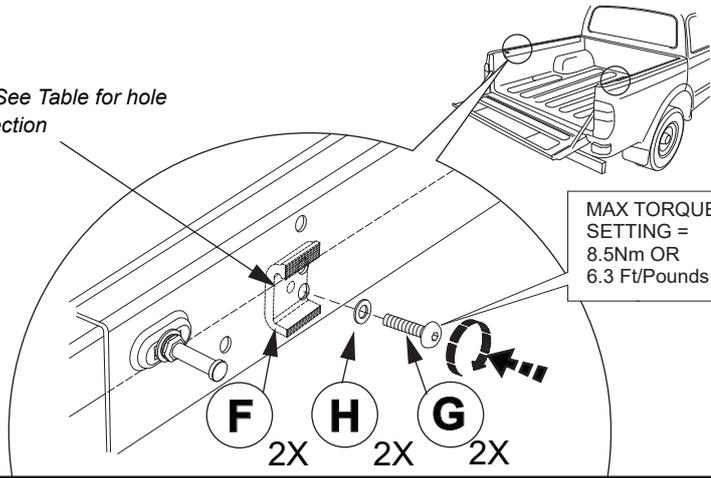

MAX TORQUE SETTING = 8.5Nm OR 6.3 Ft/Pounds

F 2X H 2X G 2X

7

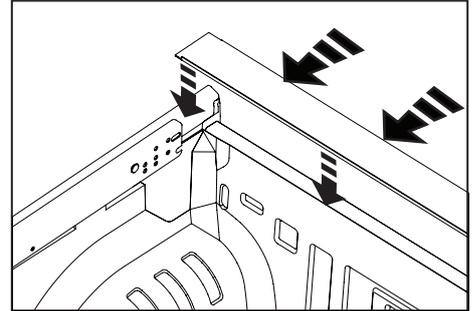
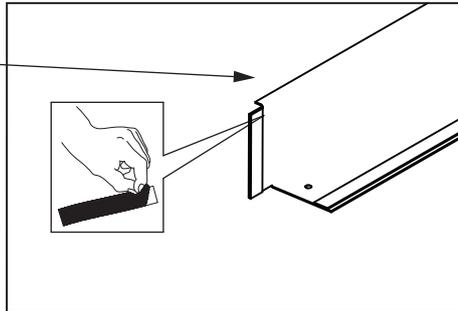
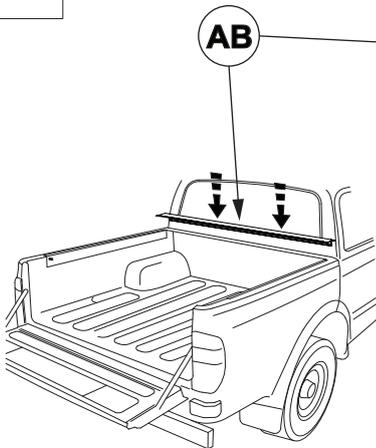

 DO NOT apply below 15°C.  
Apply pressure to part. Adhesive is pressure activated.  
Allow 3hrs minimum to cure before installing lid

NO GAP  
Press Drip Rail  
up against Front wall

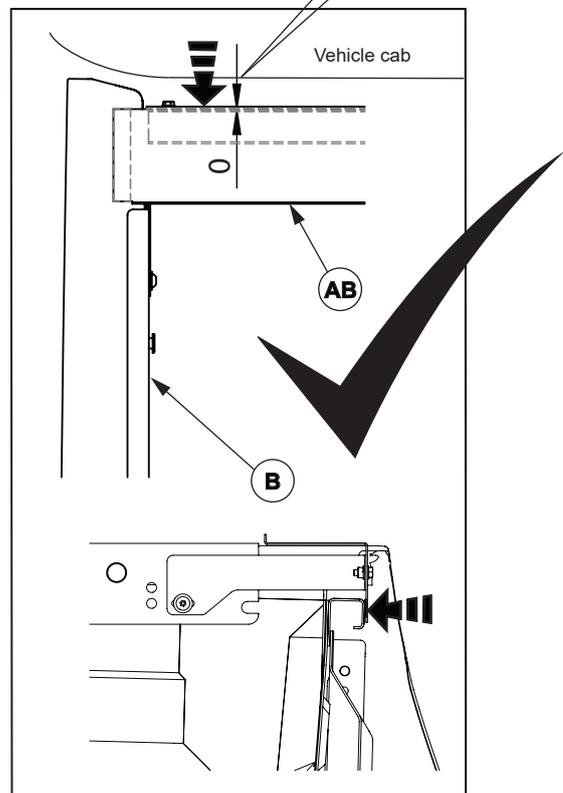
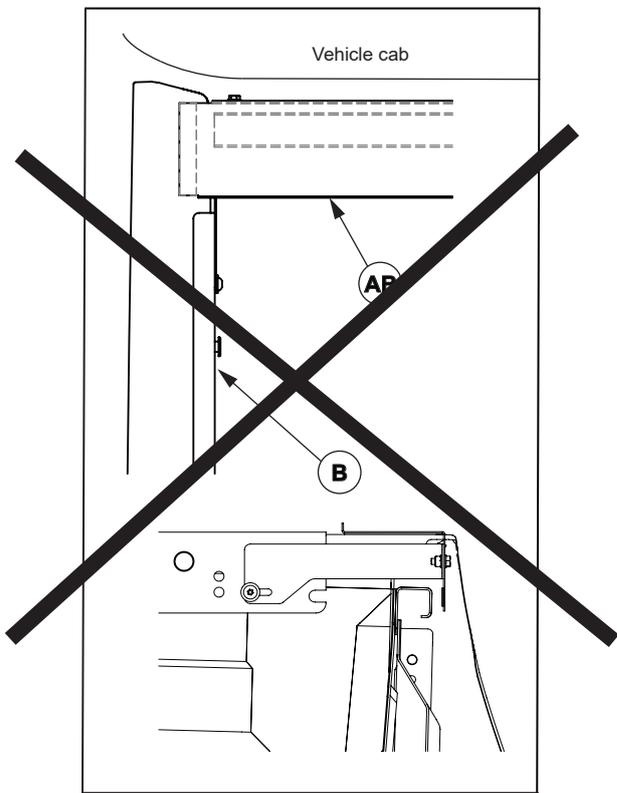

Fitting Kit Number	Product	Revision	Date	Page
K408	Upstone Lid	3	26-11-2019	4 of 8

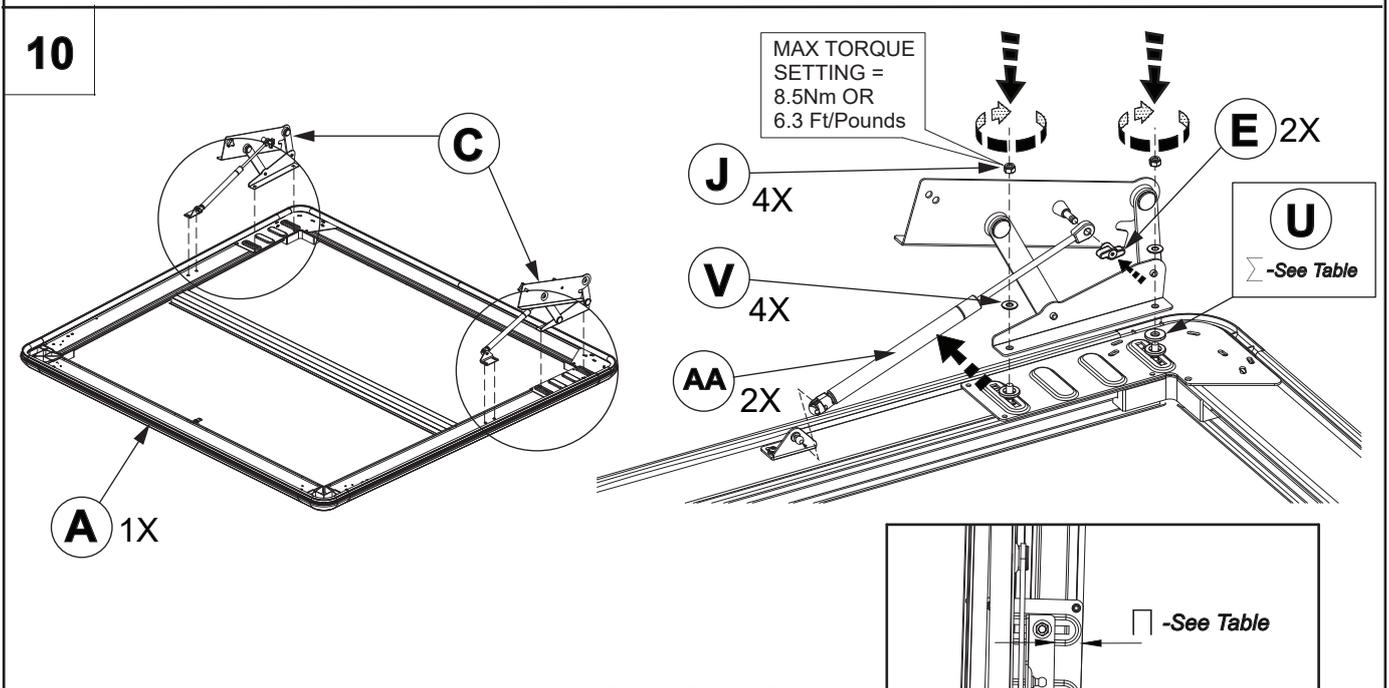
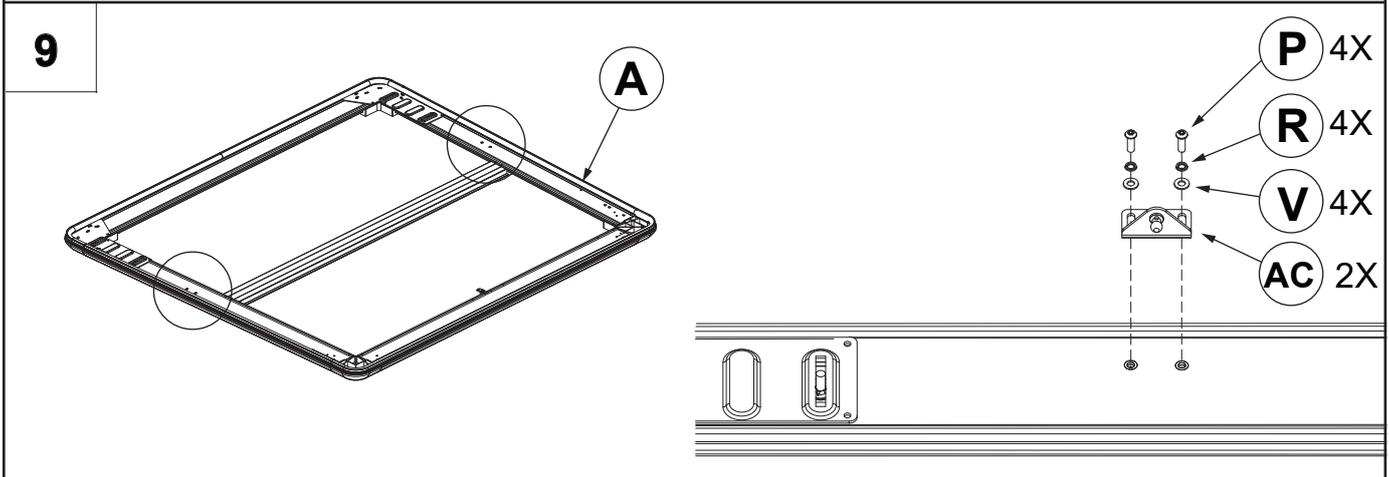
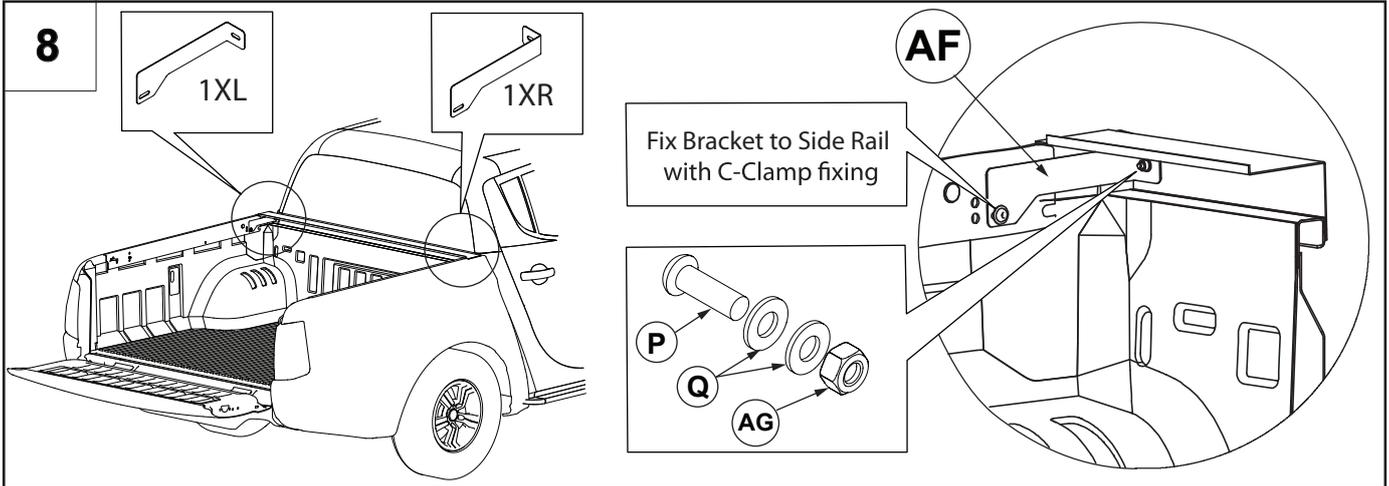

Vehicle Model	□	⊖	Σ
Mitsubishi L200 Double Cab 2016+	25mm	25mm	-
Fiat Fullback Double cab 2016+	25mm	25mm	-

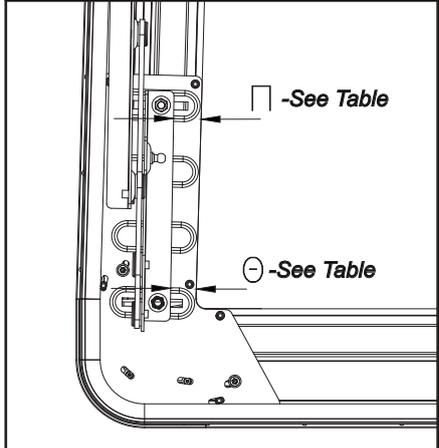

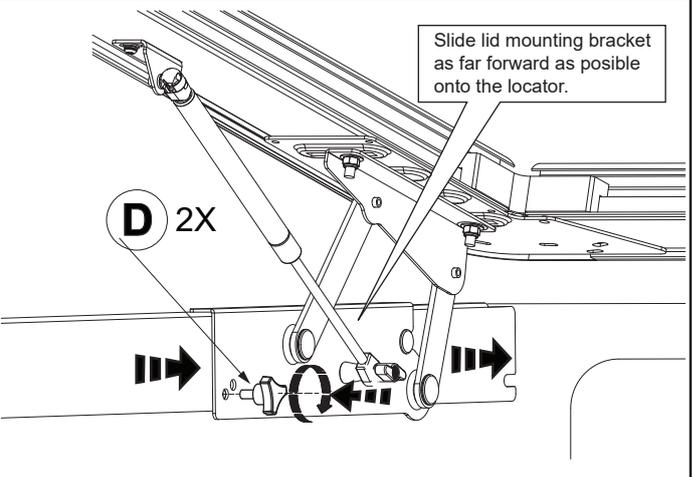
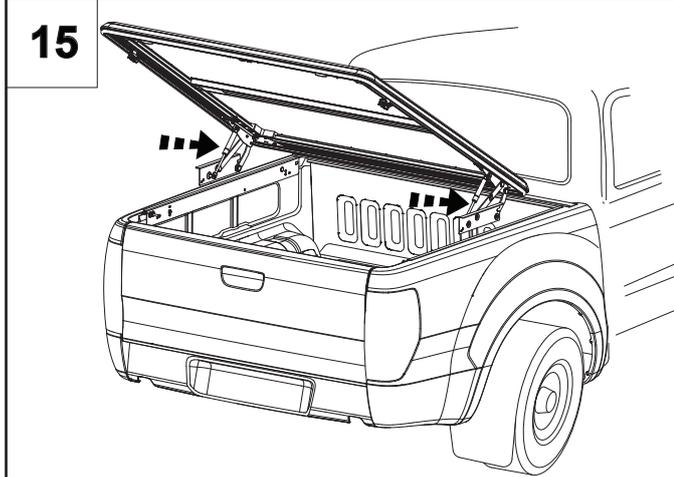
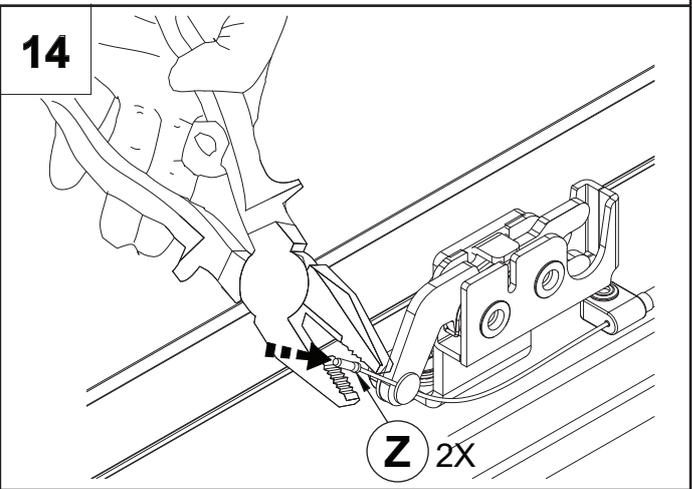
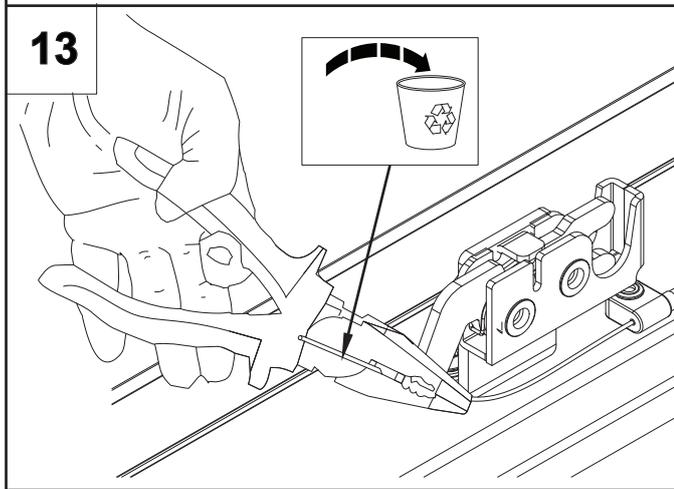
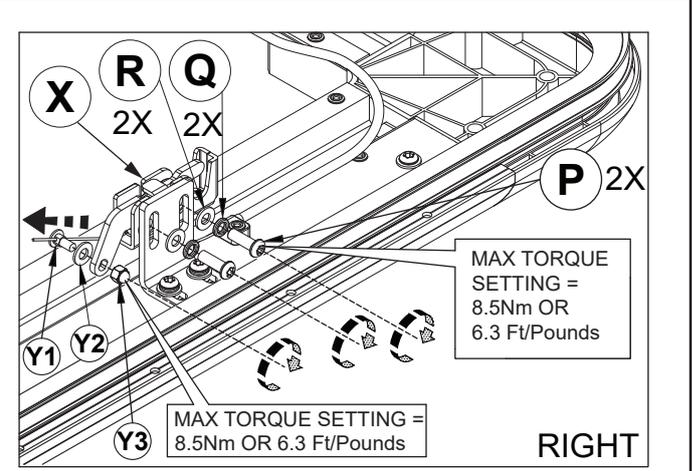
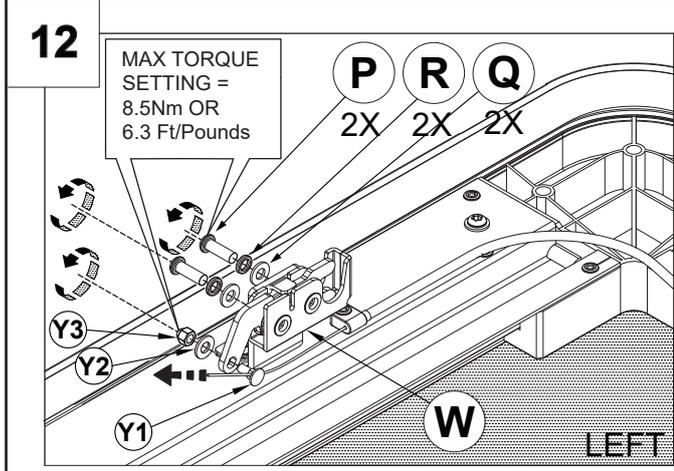
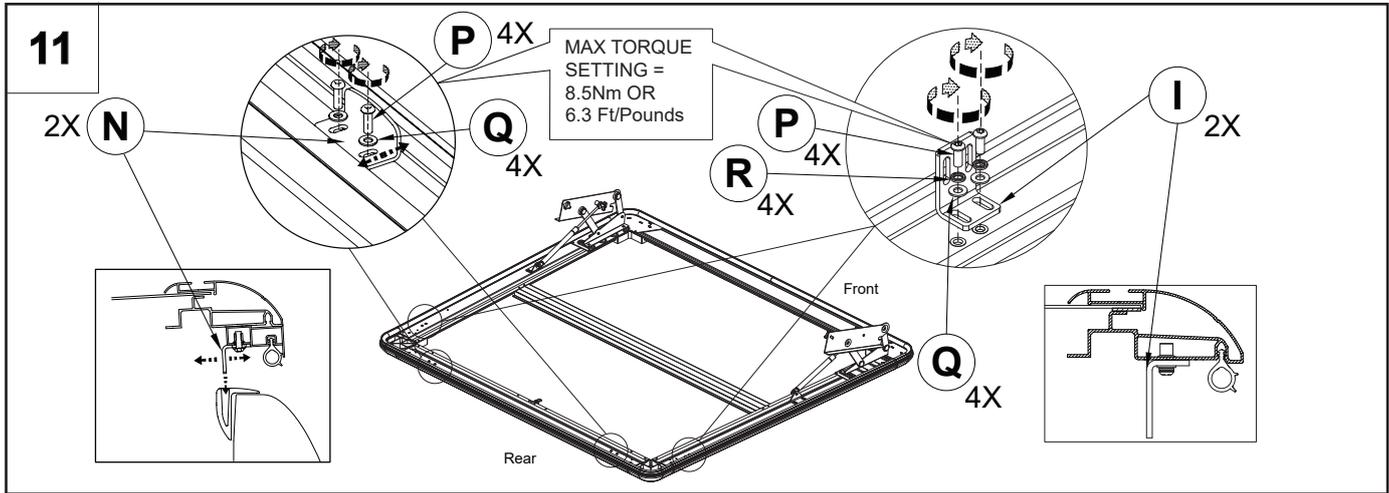

Fitting Kit Number K408	Product Upstone Lid	Revision 3	Date 26-11-2019	Page 6 of 8
----------------------------	------------------------	---------------	--------------------	----------------

16

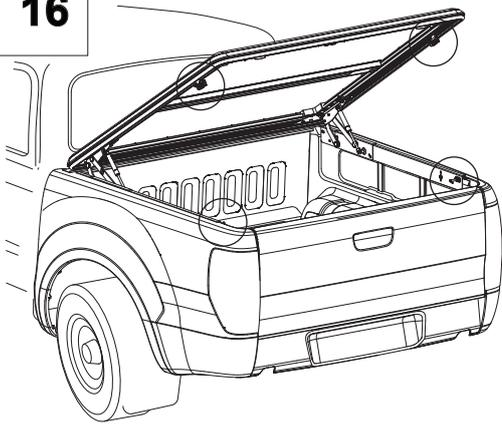

MAX TORQUE SETTING = 8.5Nm OR 6.3 Ft/Pounds

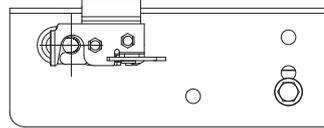
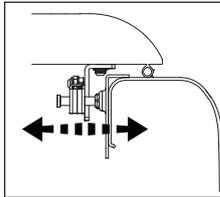
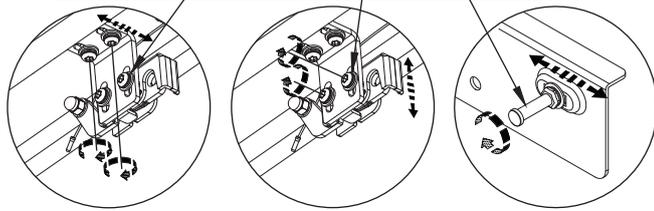

Adjust latch bracket, latch height and pin location to align pin with centre of latch. Adjust cable tension to achieve correct latching. **IMPORTANT!** : Ensure seal contacts vehicle in all areas

17

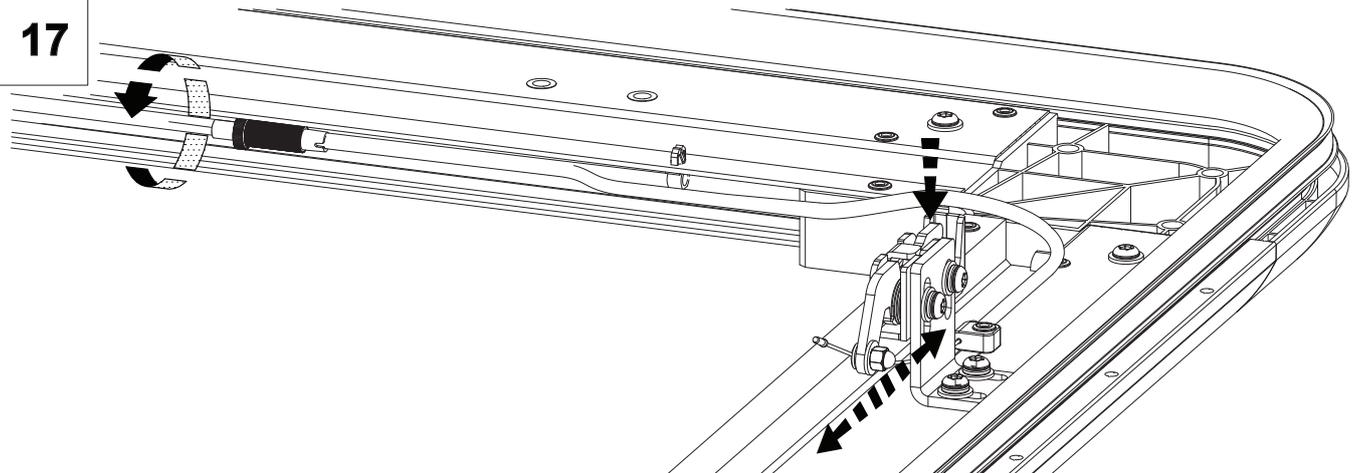

18

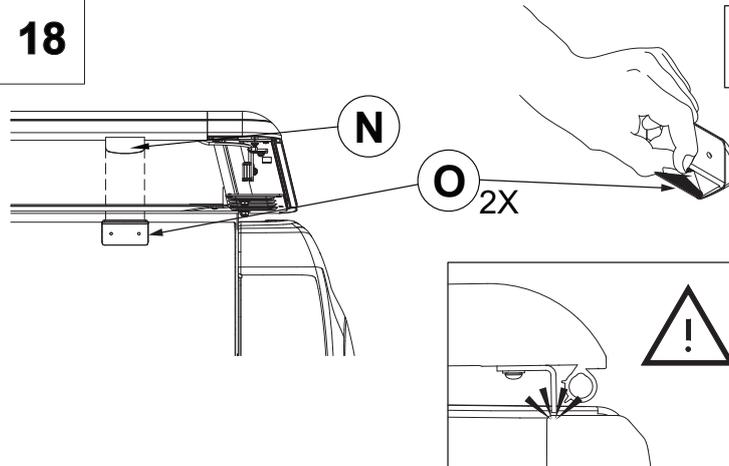

**!** DO NOT apply below 15°C. Apply pressure to part. Adhesive is pressure activated. Allow 3hrs minimum to cure.

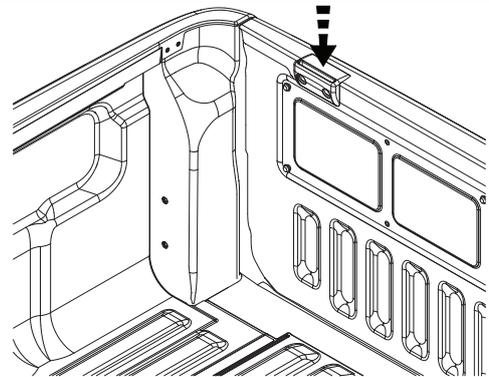

19

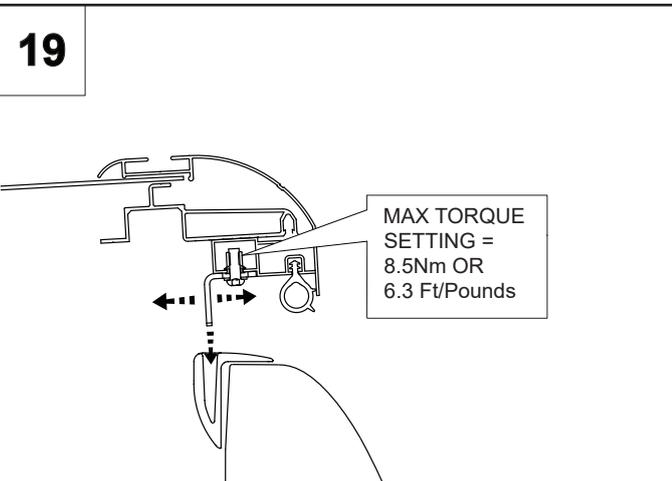

20

**!** OPTIONAL

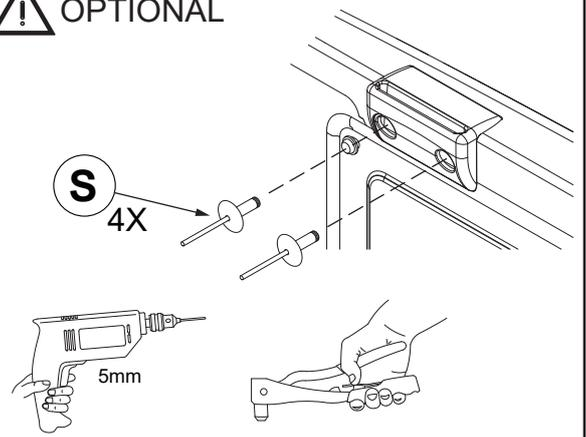

21



Insure hinge is not twisted.  
Adjust connection to lid if nessessary.

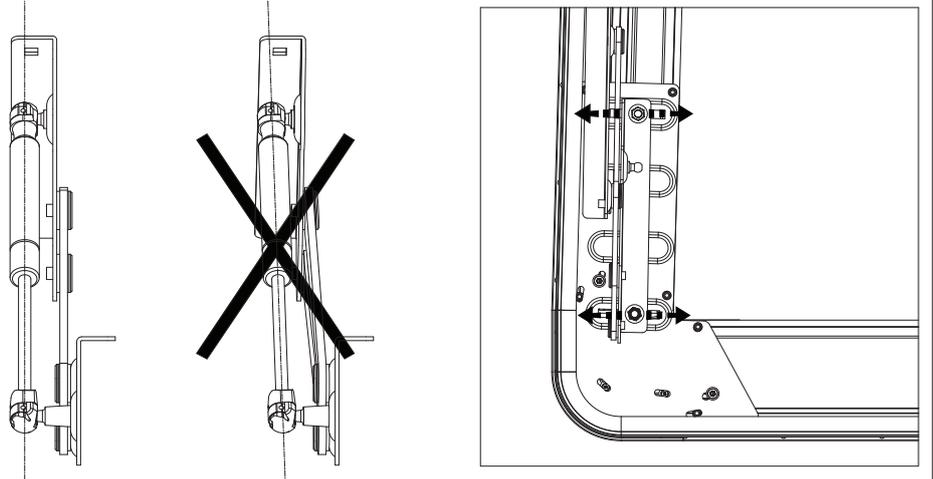

22

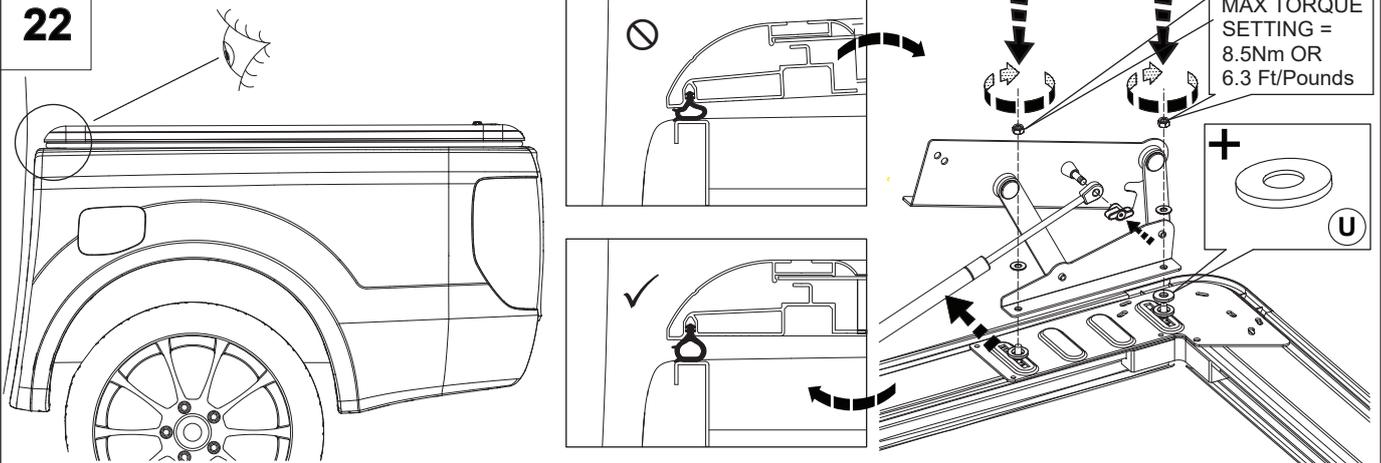

23

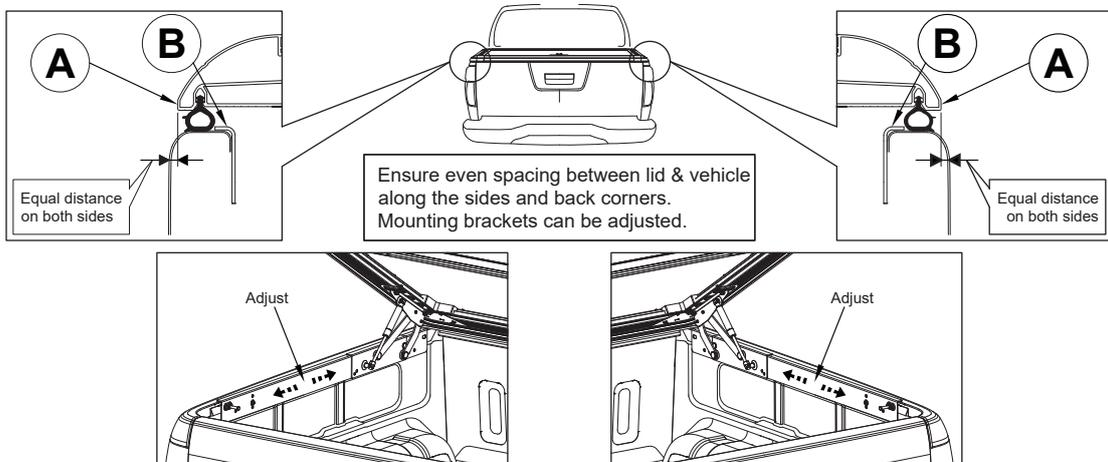

After installation carefully and thoroughly clean all debris from the inside of the cargo box.  
**Retain these instructions for future reference**

**CAUTION!**

- NEVER allow people or animals under the closed cover
- Do not place unsealed solvents or chemicals under the cover
- Do not stand or place heavy objects on the cover
- Do not open lid when under load.
- Close the cover before operating the vehicle
- Do not allow oil, solvents or chemicals to contact the cover
- Clean only with a mild detergent and water solution

Fitting Kit Number	Product	Revision	Date	Page
K408	Upstone Lid	3	26-11-2019	8 of 8